

© 威茨机械 (WENCE MACHINERY) 版权所有
♻️ 采用生态纸印刷 Adopt the ecological Paper for printing

浙江威茨机械有限公司

ZHEJIANG WENCE MACHINERY CO.,LTD.

ADD: Room 526, Building 7, Electromechanical Park,
Wuzhou International Trade City, Feiyun Street,
Ruian City, Zhejiang Province, China

TEL: +86-577-63707331

FAX: +86-577-63707332

Mob/Wechat/FB/Whatsapp:+86 15967712636 Mia Lee

Email:info@cnwence.com

gearmia@163.com

WEB: www.cnwence.com



**REDUCER MOTOR INDUSTRY
SOLUTIONS EXPERT**

减速机、电机行业解决方案专家

浙江威茨机械有限公司
ZHEJIANG WENCE MACHINERY CO.,LTD.

CH	18	400	30	SZ	B	G1	LB
機型代號 Model code	輸出軸直徑 Output shaft dia	馬力 Horsepower	減速比 Speed reducing ratio	電壓極速 Top speed of voltage	附件 Accessory	入線口方向 WIRE INLET	
CH: 臥式 CH: horizontal CV: 立式 CV: vertical	18 22 28 32 40 50	100W 200W 400W 550W 750W 1100W 1500W 2200W 3700W	1:3...1:1800	A=1 φ 110V4P C=1 φ 220V4P S=3 φ 220V4P U=3 φ 380V4P W=3 φ 440V4P Y=3 φ 220~240/ 380~440V4P Z= 縮框型減速電機 light type duty	B: DC90V安全剎車器 YB BRAKE UNIT :手釋放剎車器 WITH RELEASE BRAKE UNIT D: DC24V送電剎車器 DC24V BRAKE	依出力軸看配線盒方向 VIEW FROM OUTPUT SHAFT G1: 左方向(標準型) LEFT (STD) G2: 右方向 RIGHT G3: 上方向 UPPER G4: 下方向 LOWER	
						T: 向上 TOP D: 向下 DOWN F: 向前 FORWARD B: 向後 BACK L: 向左 LEFT R: 向右 RIGHT	



配線盒方向選定
(TERMINAL BOX DIRECTION)

TYPE	G1-左方向 LEFT SIDE	G2-右方向 RIGHT SIDE	G3-上方向 UPPER SIDE	G4-下方向 LOWER SIDE
CH型 CH TYPE				
	G1	G2	G3	G4
CV型 CV TYPE				
	G1	G2	G3	G4

入線口方向
(WIRE INLET DIRECTION)

LD	LT	RD	RT	TL	TR	DL	DR
LF	LB	RF	RB	TF	TB	DF	DB

減速機與透氣塞安裝位置示意圖

(REDUCER AND VENTILATION INSTALLATION)

CH 機型安裝範例			
	H0標準(Standard)(CPG正立CPG STAND)	H3(左側LEFT SIDE)	H6(倒裝INVERT)
	H9(右側RIGHT SIDE)	HU(軸向上SHAFT UP)	HD(軸向下SHAFT DOWN)
CH 機型安裝範例			
	V0標準(Standard)(CPG正立CPG STAND)	V3(CPG旋轉90° CPG CLOCKWISE 90°)	V6(CPG旋轉180° CPG CLOCKWISE 180°)
	V9(CPG逆轉90° CPG LEFT TURN 90°)	VU(軸向上SHAFT UP)	VD(軸向下SHAFT DOWN)



0.1KW

CH 型卧式三相鋁殼 (剎車) 馬達減速機

CH HORIZONTAL TYPE WITH ALUMINON PLATE 3PHASE(BRAKE)GEAR MOTOR

馬達尺寸圖 Dimensions chart

單位: mm

標準型 CH-18-100-3~60

Mormal Duty Type CH-18-100-3~60

輕負載縮框型 CH-18-100-70~200

Light load miniature frame CH-18-100-70~200

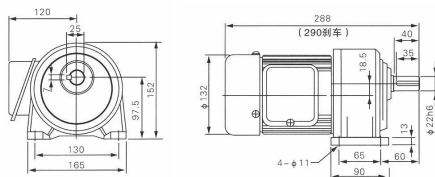
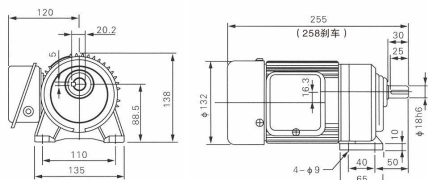

CV 型立式三相鋁殼 (剎車) 馬達減速機

CV RTICAL TYPE WITH ALUMINON PLATE 3PHASE(BRAKE)GEAR MOTOR

馬達尺寸圖 Dimensions chart

標準型 CV-18-100-3~60

Mormal Duty Type CV-18-100-3~60

輕負載縮框型 CH-18-100-70~200

Light load miniature frame CH-18-100-70~200

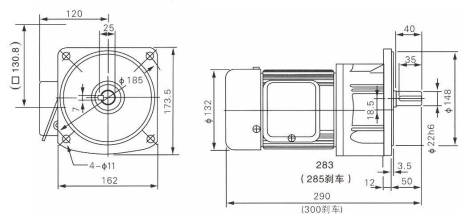
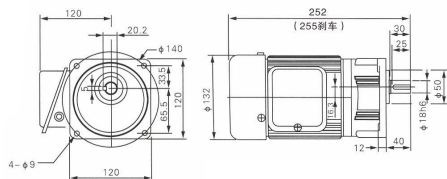

0.2KW

馬達尺寸圖 Dimensions chart

單位: mm

CH 型卧式三相鋁殼 (剎車) 馬達減速機

CH HORIZONTAL TYPE WITH ALUMINON PLATE 3PHASE(BRAKE)GEAR MOTOR

標準型 CH-18-200-3~10

Mormal Duty Type CH-18-200-3~10

輕負載縮框型 CH-18-200-15~90

Light load miniature frame CH-18-200-15~90

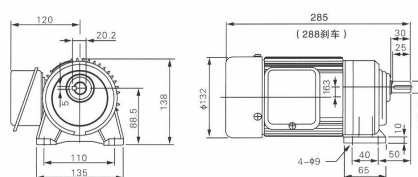

標準型 CH-22-200-15~90

Mormal Duty Type CH-22-200-15~90

輕負載縮框型 CH-22-200-100~200

Light load miniature frame CH-22-200-100~200

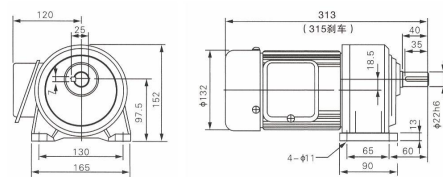

標準型 CH-28-200-100~200

Mormal Duty Type CH-28-200-100~200

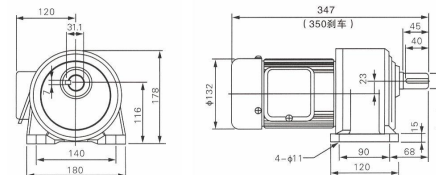

CV 型立式三相鋁殼 (剎車) 馬達減速機

CV RTICAL TYPE WITH ALUMINON PLATE 3PHASE(BRAKE)GEAR MOTOR

標準型 CV-18-200-3~10

Mormal Duty Type CV-18-200-3~10

輕負載縮框型 CH-18-200-15~90

Light load miniature frame CH-18-200-15~90

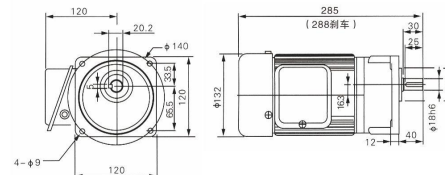

標準型 CV-22-200-15~90

Mormal Duty Type CV-22-200-15~90

輕負載縮框型 CV-22-200-100~200

Light load miniature frame CV-22-200-100~200

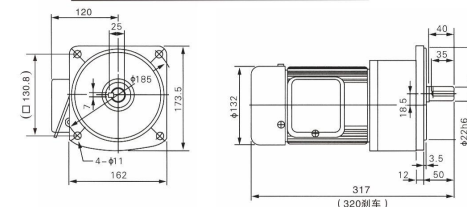

標準型 CV-28-200-100~200

Mormal Duty Type CV-28-200-100~200

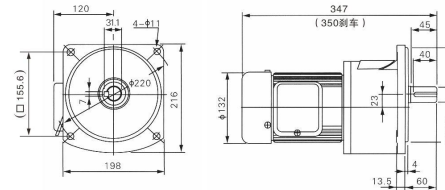



0.4KW

CH 型卧式三相鋁殼 (剎車) 馬達減速機

CH HORIZONTAL TYPE WITH ALUMINON PLATE 3PHASE(BRAKE)GEAR MOTOR

馬達尺寸圖 Dimensions chart

單位: mm

標準型 CH-22-400-3~10

Normal Duty Type CH-22-400-3~10
輕負載縮框型 CH-22-400-15~90
Light load miniature frame CH-22-400-15~90

標準型 CH-22-400-3~10

Normal Duty Type CH-22-400-3~10
輕負載縮框型 CH-22-400-15~90
Light load miniature frame CH-22-400-15~90

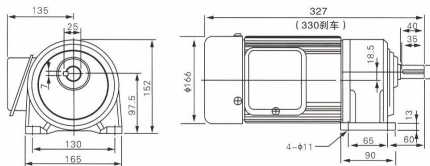
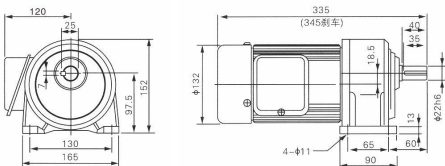

標準型 CH-28-400-15~90

Normal Duty Type CH-28-400-15~90
輕負載縮框型 CH-28-400-100~200
Light load miniature frame CH-28-400-100~200

標準型 CH-32-400-100~200

Normal Duty Type CH-32-400-100~200

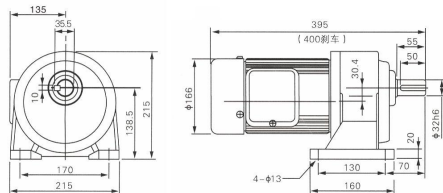
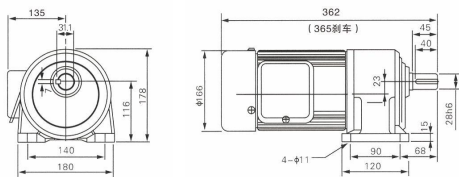

注: 縮框型為輕負載, 無大慣性場合中使用。為不正當設計, 如非必要請勿使用
Note: miniature frame is light load, without being used in big inertia condition. This improper design is not allowed to use unless necessary.



0.4KW

CV 型立式三相鋁殼 (剎車) 馬達減速機

CV RTICAL TYPE WITH ALUMINON PLATE 3PHASE(BRAKE)GEAR MOTOR

馬達尺寸圖 Dimensions chart

單位: mm

標準型 CV-22-400-3~10

Normal Duty Type CV-22-400-3~10
輕負載縮框型 CV-22-400-15~90
Light load miniature frame CV-22-400-15~90

標準型 CV-22-400-3~10

Normal Duty Type CV-22-400-3~10
輕負載縮框型 CV-22-400-15~90
Light load miniature frame CV-22-400-15~90

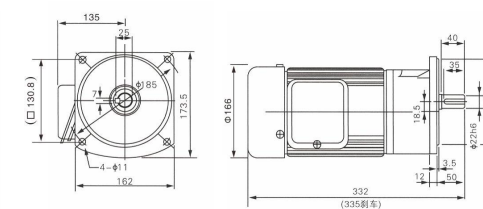
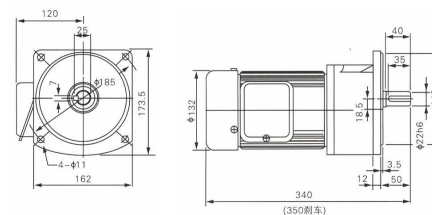

標準型 CV-28-400-15~90

Normal Duty Type CV-28-400-15~90
輕負載縮框型 CV-28-400-100~200
Light load miniature frame CV-28-400-100~200

標準型 CV-32-400-100~200

Normal Duty Type CV-32-400-100~200

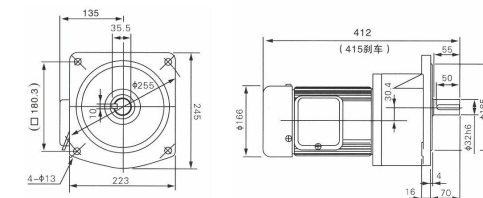
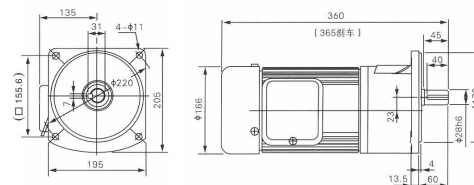

注: 縮框型為輕負載, 無大慣性場合中使用。為不正當設計, 如非必要請勿使用
Note: miniature frame is light load, without being used in big inertia condition. This improper design is not allowed to use unless necessary.



0.55KW

CH 型卧式三相鋁殼 (剎車) 馬達減速機
CH HORIZONTAL TYPE WITH ALUMINON PLATE 3PHASE(BRAKE)GEAR MOTOR

馬達尺寸圖 Dimensions chart

單位: mm

輕負載縮框型 **CH-22-550-3~25**
Light load miniature frame CH-22-550-3~25

標準型 CH-28-550-3~25
Normal Duty Type CH-28-550-3~25
輕負載縮框型 CH-28-550-30~120
Light load miniature frame CH-28-550-30~120

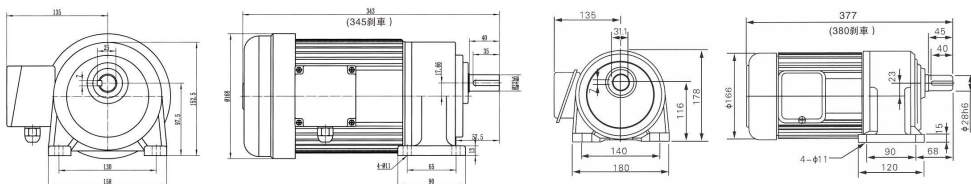

標準型 CH-32-550-30~120
Normal Duty Type CH-32-550-30~120
輕負載縮框型 CH-32-550-130~200
Light load miniature frame CH-32-550-130~200

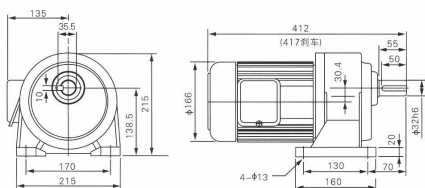

注: 縮框型為輕負載, 無大慣性場合中使用。為不正當設計, 如非必要請勿使用
Note: miniature frame is light load, without being used in big inertia condition. This improper design is not allowed to use unless necessary.



0.55KW

CV 型立式三相鋁殼 (剎車) 馬達減速機
CV RTICAL TYPE WITH ALUMINON PLATE 3PHASE(BRAKE)GEAR MOTOR

馬達尺寸圖 Dimensions chart

單位: mm

輕負載縮框型 **CV-22-550-3~25**
Light load miniature frame CV-22-550-3~25

標準型 CV-28-550-3~25
Normal Duty Type CV-28-550-3~25
輕負載縮框型 CV-28-550-30~120
Light load miniature frame CV-28-550-30~120

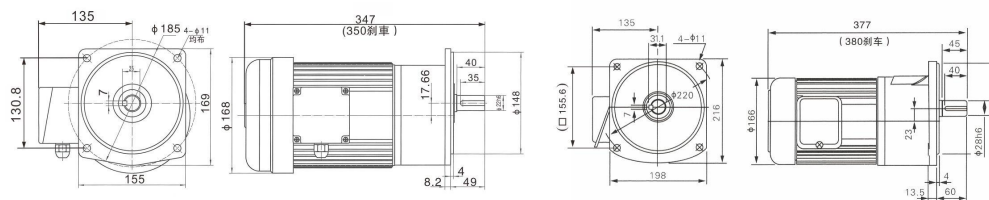

標準型 CV-32-550-30~120
Normal Duty Type CV-32-550-30~120
輕負載縮框型 CV-32-550-130~200
Light load miniature frame CV-32-550-130~200

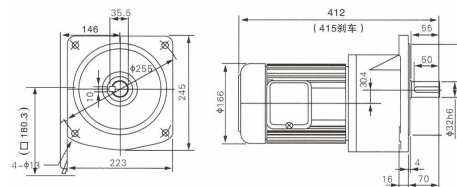

注: 縮框型為輕負載, 無大慣性場合中使用。為不正當設計, 如非必要請勿使用
Note: miniature frame is light load, without being used in big inertia condition. This improper design is not allowed to use unless necessary.



0.75KW

CH 型卧式三相鋁殼 (剎車) 馬達減速機
CH HORIZONTAL TYPE WITH ALUMINON PLATE 3PHASE(BRAKE)GEAR MOTOR

馬達尺寸圖 Dimensions chart

單位: mm

輕負載縮框型 **CH-22-750-3~25**
Light load miniature frame CH-22-750-3~25

標準型 **CH-28-750-3~25**
輕負載縮框型 CH-28-750-30~120
Light load miniature frame CH-28-750-30~120

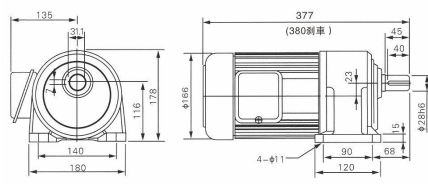
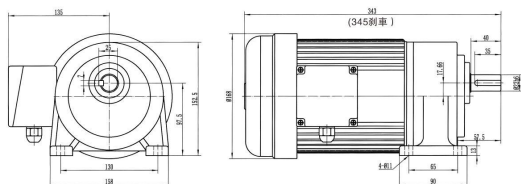

標準型 **CH-32-750-30~120**
Normal Duty Type CH-32-750-30~120
輕負載縮框型 CH-32-750-130~200
Light load miniature frame CH-32-750-130~200

標準型 **CH-40-750-130~200**
Normal Duty Type CH-40-750-130~200

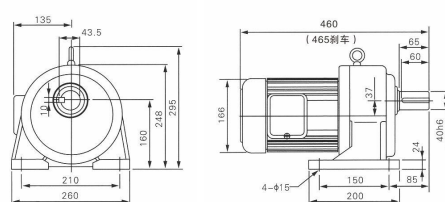
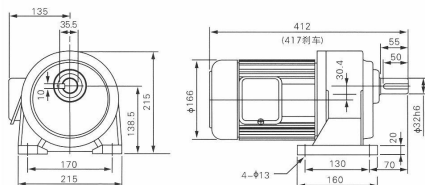

注: 縮框型為輕負載, 無大慣性場合中使用。為不正當設計, 如非必要請勿使用
Note: miniature frame is light load, without being used in big inertia condition. This improper design is not allowed to use unless necessary.



0.75KW

CV 型立式三相鋁殼 (剎車) 馬達減速機
CV RTICAL TYPE WITH ALUMINON PLATE 3PHASE(BRAKE)GEAR MOTOR

馬達尺寸圖 Dimensions chart

單位: mm

輕負載縮框型 **CV-22-750-3~25**
Light load miniature frame CV-22-750-3~25

標準型 **CV-28-750-3~25**
Normal Duty Type CV-28-750-3~25
輕負載縮框型 CV-28-750-30~120
Light load miniature frame CV-28-750-30~120

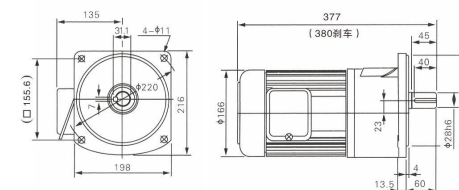
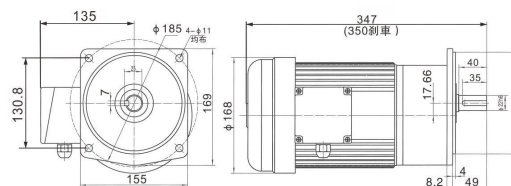

標準型 **CV-32-750-30~120**
Normal Duty Type CV-32-750-30~120
輕負載縮框型 CV-32-750-130~200
Light load miniature frame CV-32-750-130~200

標準型 **CV-40-750-100~200**
Normal Duty Type CV-40-750-100~200

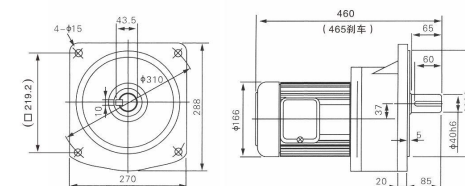
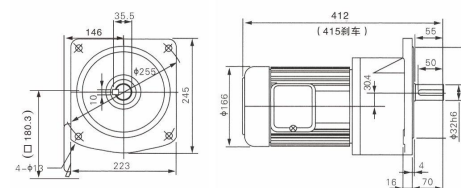

注: 縮框型為輕負載, 無大慣性場合中使用。為不正當設計, 如非必要請勿使用
Note: miniature frame is light load, without being used in big inertia condition. This improper design is not allowed to use unless necessary.



1.1 KW

CH 型卧式三相鋁殼 (剎車) 馬達減速機
CH HORIZONTAL TYPE WITH ALUMINON PLATE 3PHASE(BRAKE)GEAR MOTOR

馬達尺寸圖 Dimensions chart

單位: mm

標準型 CH-28-1100-3~25

Mormal Duty Type CH-28-1100-3~25
輕負載縮框型 CH-28-1100-30~100
Light load miniature frame CH-28-1100-30~100

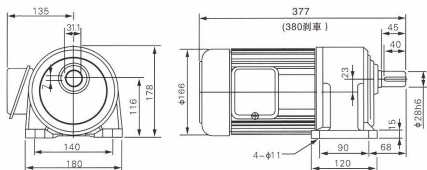

標準型 CH-32-1100-30~50

Mormal Duty Type CH-32-1100-30~50
輕負載縮框型 CH-32-1100-60~160
Light load miniature frame CH-32-1100-60~160

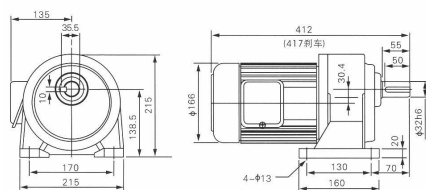

標準型 CH-40-1100-130~200

Mormal Duty Type CH-40-1100-130~200

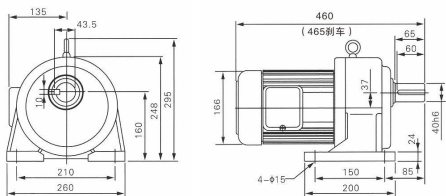

注: 縮框型為輕負載, 無大慣性場合中使用。為不正當設計, 如非必要請勿使用
Note: miniature frame is light load, without being used in big inertia condition. This improper design is not allowed to use unless necessary.



1.1 KW

CV 型立式三相鋁殼 (剎車) 馬達減速機
CV RTICAL TYPE WITH ALUMINON PLATE 3PHASE(BRAKE)GEAR MOTOR

馬達尺寸圖 Dimensions chart

單位: mm

標準型 CV-28-1100-3~25

Mormal Duty Type CV-28-1100-3~25
輕負載縮框型 CV-28-1100-30~100
Light load miniature frame CV-28-1100-30~100

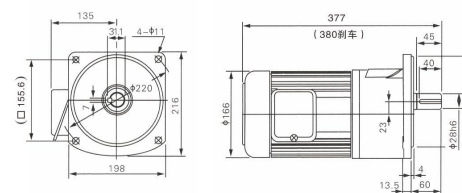

標準型 CV-32-1100-30~50

Mormal Duty Type CV-32-1100-30~50
輕負載縮框型 CV-32-1100-60~160
Light load miniature frame CV-32-1100-60~160

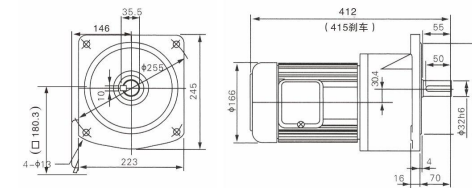

標準型 CV-40-1100-130~200

Mormal Duty Type CV-40-1100-130~200

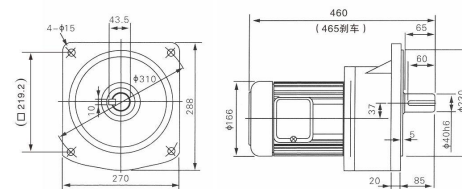

注: 縮框型為輕負載, 無大慣性場合中使用。為不正當設計, 如非必要請勿使用
Note: miniature frame is light load, without being used in big inertia condition. This improper design is not allowed to use unless necessary.



1.5KW

CH 型卧式三相鋁殼 (剎車) 馬達減速機

CH HORIZONTAL TYPE WITH ALUMINON PLATE 3PHASE(BRAKE)GEAR MOTOR

馬達尺寸圖 Dimensions chart

單位: mm

輕負載縮框型 **CH-28-1500-3~25**
Light load miniature frame CH-28-1500-3~25

標準型 **CH-32-1500-3~30**
Mormal Duty Type CH-32-1500-3~30
輕負載縮框型 CH-32-1500-40~90
Light load miniature frame CH-32-1500-40~90

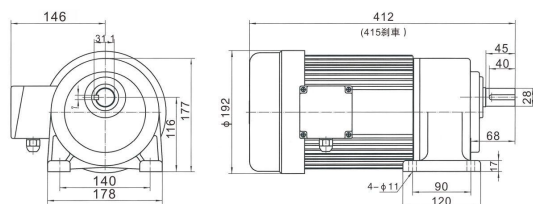

標準型 **CH-40-1500-35~100**
Mormal Duty Type CH-40-1500-35~100
輕負載縮框型 CH-40-1500-110~200
Light load miniature frame CH-40-1500-110~200

標準型 **CH-50-1500-110~200**
Mormal Duty Type CH-50-1500-110~200

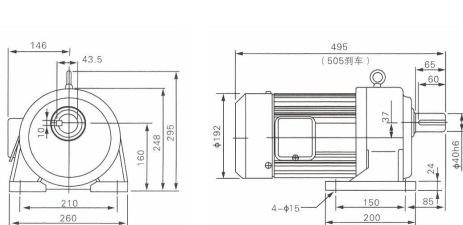

注: 縮框型為輕負載, 無大慣性場合中使用。為不正當設計, 如非必要請勿使用
Note: miniature frame is light load, without being used in big inertia condition. This improper design is not allowed to use unless necessary.



1.5KW

CV 型立式三相鋁殼 (剎車) 馬達減速機

CV RTICAL TYPE WITH ALUMINON PLATE 3PHASE(BRAKE)GEAR MOTOR

馬達尺寸圖 Dimensions chart

單位: mm

輕負載縮框型 **CV-28-1500-3~25**
Light load miniature frame CV-28-1500-3~25

標準型 **CV-32-1500-3~30**
Mormal Duty Type CV-32-1500-3~30
輕負載縮框型 CV-32-1500-40~100
Light load miniature frame CV-32-1500-40~100

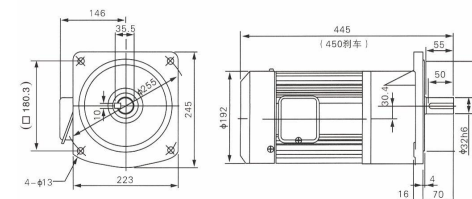
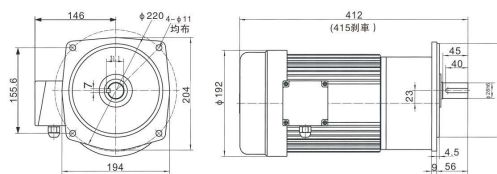

標準型 **CV-40-1500-35~100**
Mormal Duty Type CV-40-1500-35~100
輕負載縮框型 CV-40-1500-110~200
Light load miniature frame CV-40-1500-110~200

標準型 **CV-50-1500-110~200**
Mormal Duty Type CV-50-1500-110~200

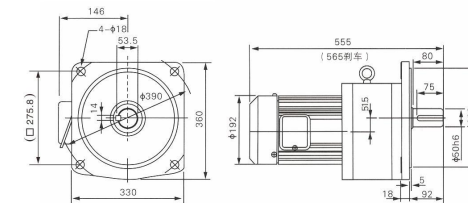
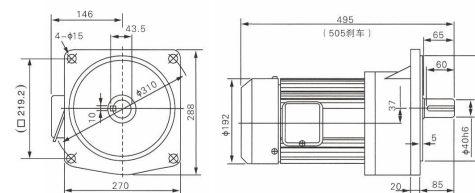

注: 縮框型為輕負載, 無大慣性場合中使用。為不正當設計, 如非必要請勿使用
Note: miniature frame is light load, without being used in big inertia condition. This improper design is not allowed to use unless necessary.



2.2KW

CH 型卧式三相鋁殼 (剎車) 馬達減速機

CH HORIZONTAL TYPE WITH ALUMINON PLATE 3PHASE(BRAKE)GEAR MOTOR

馬達尺寸圖 Dimensions chart

單位: mm

標準型 CH-40-2200-3~40

Mormal Duty Type CH-40-2200-3~40

輕負載縮框型 CH-40-2200-50~80

Light load miniature frame CH-40-2200-50~80

標準型 CH-50-2200-50~100

Mormal Duty Type CH-50-2200-50~100

輕負載縮框型 CH-50-2200-100~200

Light load miniature frame CH-50-2200-100~200

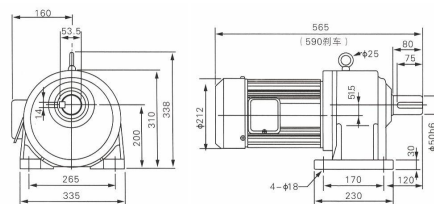
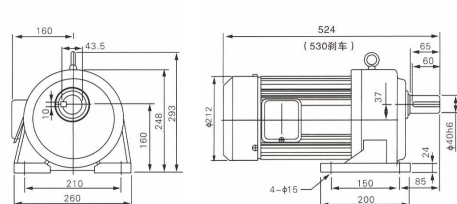

CV 型立式三相鋁殼 (剎車) 馬達減速機

CV RTICAL TYPE WITH ALUMINON PLATE 3PHASE(BRAKE)GEAR MOTOR

馬達尺寸圖 Dimensions chart

單位: mm

標準型 CV-40-2200-3~40

Mormal Duty Type CV-40-2200-3~40

輕負載縮框型 CV-40-2200-50~80

Light load miniature frame CV-40-2200-50~80

標準型 CV-50-2200-50~100

Mormal Duty Type CV-50-2200-50~100

輕負載縮框型 CV-50-2200-110~200

Light load miniature frame CV-50-2200-110~200

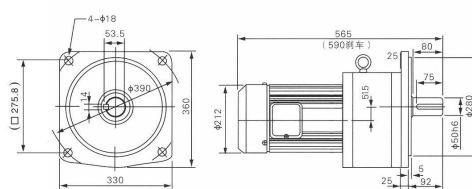
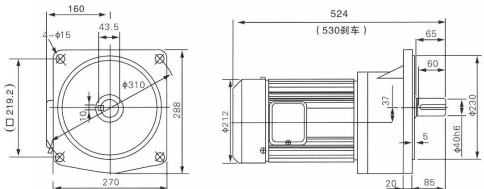

3.7KW

CH 型卧式三相鋁殼 (剎車) 馬達減速機

CH HORIZONTAL TYPE WITH ALUMINON PLATE 3PHASE(BRAKE)GEAR MOTOR

馬達尺寸圖 Dimensions chart

單位: mm

標準型 CH-40-3700-3~10

Mormal Duty Type CH-40-3700-3~10

輕負載縮框型 CH-40-15~60

Light load miniature frame CH-40-15~60

標準型 CH-50-3700-15~60

Mormal Duty Type CH-50-3700-15~60

輕負載縮框型 CH-50-3700-70~200

Light load miniature frame CH-50-3700-70~200

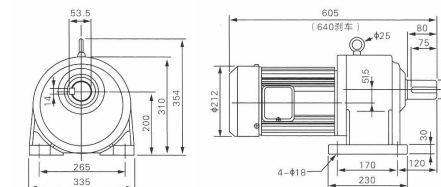
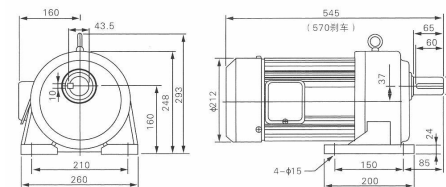

CV 型立式三相鋁殼 (剎車) 馬達減速機

CV RTICAL TYPE WITH ALUMINON PLATE 3PHASE(BRAKE)GEAR MOTOR

馬達尺寸圖 Dimensions chart

單位: mm

標準型 CV-40-3700-3~10

Mormal Duty Type CV-40-3700-3~10

輕負載縮框型 CV-50-3700-15~60

Light load miniature frame CV-50-3700-15~60

標準型 CV-50-3700-15~60

Mormal Duty Type CV-50-3700-15~60

輕負載縮框型 CV-50-3700-70~200

Light load miniature frame CV-50-3700-70~200

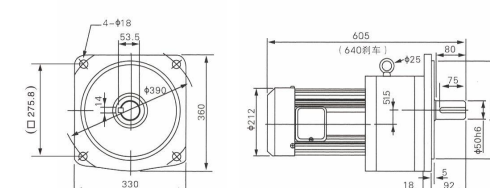
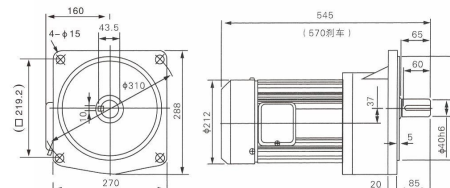

CH、CV組合型三相鋁殼（剎車）馬達減速機
CH、CV combined three-phase aluminum (brake) motor speed reducer

馬達尺寸圖 Dimensions chart
輕負載縮框型 Light load miniature frame

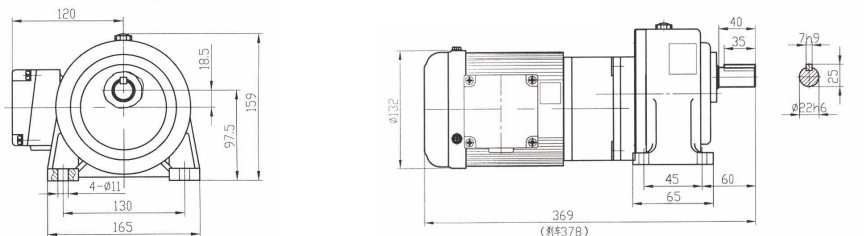

CH28+CH18-100-250~1800

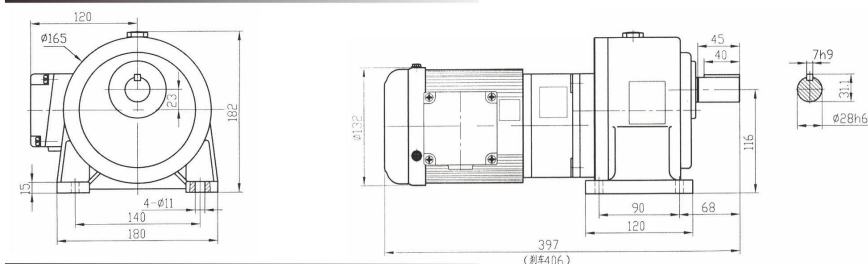

CV22+CV18-100-250~1800
輕負載縮框型 Light load miniature frame

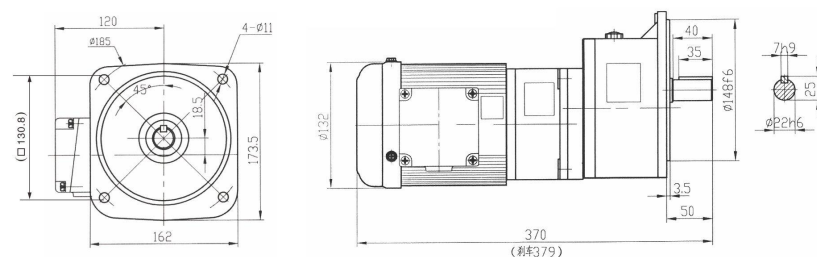

CV28+CV18-100-250~1800

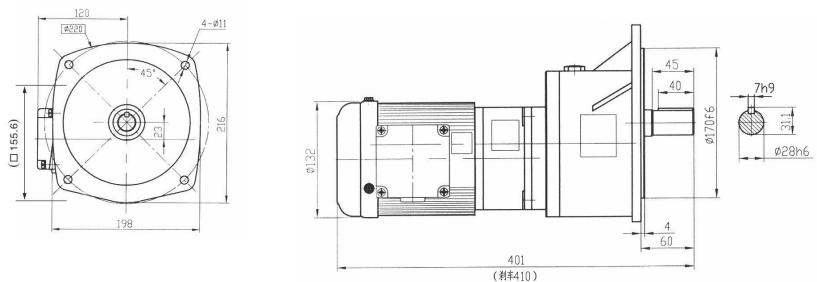

產品結構圖 Product Structure Drawing

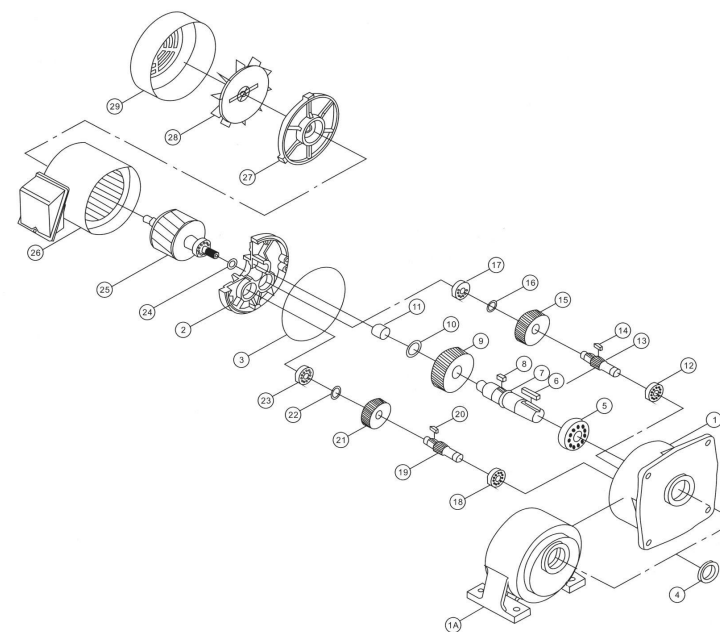

序號 Item	品名 denomination
1	本體 housing
2	本體蓋housing cover
3	O型環 o-ring
4	出力軸油封 oil seal
5	培林 ball bearing
6	鍵 key
7	出力軸 out put shaft
8	鍵 key
9	三段大齒輪 3rd main gear
10	扣環 snap ring

序號 Item	品名 denomination
11	培林 ball bearing
12	培林 ball bearing
13	三段大齒輪 3rd main gear
14	鍵 key
15	二段大齒輪 2rd main gear
16	扣環 snap ring
17	培林 ball bearing
18	培林 ball bearing
19	二段大齒輪 2rd main gear
20	鍵 key

序號 Item	品名 denomination
21	一段大齒輪 1rd main gear
22	扣環 snap ring
23	培林 ball bearing
24	入力軸油封 oil seal
25	馬達軸及轉子 motor shaft
26	繞圈總成 coil assembly
27	接線盒 wire box
28	馬達後蓋 Rear cover motr
29	風扇 Fan
30	風罩 Fan cover

鍵/鍵槽加工尺寸 (KEY/KEY WAY DIMENSION)

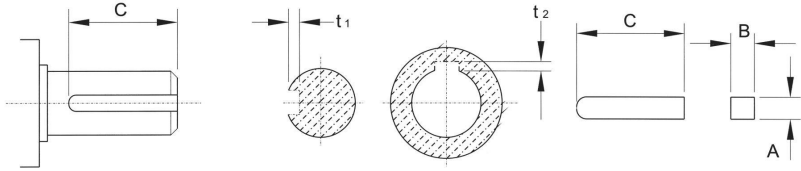

軸徑 SHAFT DIA	鍵 KEY		鍵槽 KEYWAY			
	新JIS規範 NEW JIS SPEC	舊JIS規範 OLD JIS SPEC	新JIS規範 NEW JIS SPEC (SHAFT/HOLE)		舊JIS規範 OLD JIS SPEC (SHAFT/HOLE)	
S	AxBxC	AxBxC	t1	t2	t1	t2
φ 11.0	4x4xC	4x4xC	2.5 ⁺⁰ _{+0.1}	1.8 ⁺⁰ _{+0.1}	2.5 ⁺⁰ _{+0.1}	2.0 ⁺⁰ _{+0.1}
φ 14.0	5x5xC	5x5xC	3.0 ⁺⁰ _{+0.1}	2.3 ⁺⁰ _{+0.1}	3.0 ⁺⁰ _{+0.1}	2.5 ⁺⁰ _{+0.1}
φ 18.0	6x6xC	6x6xC	3.5 ⁺⁰ _{+0.1}	2.8 ⁺⁰ _{+0.1}	3.5 ⁺⁰ _{+0.1}	3.0 ⁺⁰ _{+0.1}
φ 19.0	6x6xC	6x6xC	3.5 ⁺⁰ _{+0.1}	2.8 ⁺⁰ _{+0.1}	3.5 ⁺⁰ _{+0.1}	3.0 ⁺⁰ _{+0.1}
φ 22.0	8x7xC	7x7xC	4.0 ⁺⁰ _{+0.1}	3.3 ⁺⁰ _{+0.1}	4.0 ⁺⁰ _{+0.1}	3.5 ⁺⁰ _{+0.1}
φ 24.0	8x7xC	8x7xC	4.0 ⁺⁰ _{+0.2}	3.3 ⁺⁰ _{+0.2}	4.0 ⁺⁰ _{+0.2}	3.5 ⁺⁰ _{+0.2}
φ 28.0	8x7xC	8x7xC	4.0 ⁺⁰ _{+0.2}	3.3 ⁺⁰ _{+0.2}	4.0 ⁺⁰ _{+0.2}	3.5 ⁺⁰ _{+0.2}
φ 32.0	10x8xC	10x8xC	5.0 ⁺⁰ _{+0.2}	3.3 ⁺⁰ _{+0.2}	4.5 ⁺⁰ _{+0.2}	4.0 ⁺⁰ _{+0.2}
φ 40.0	12x8xC	12x8xC	5.0 ⁺⁰ _{+0.2}	3.3 ⁺⁰ _{+0.2}	4.5 ⁺⁰ _{+0.2}	4.0 ⁺⁰ _{+0.2}
φ 45.0	14x9xC	12x8xC	5.5 ⁺⁰ _{+0.2}	3.8 ⁺⁰ _{+0.2}	4.5 ⁺⁰ _{+0.2}	4.0 ⁺⁰ _{+0.2}
φ 50.0	14x9xC	15x10xC	5.5 ⁺⁰ _{+0.2}	3.8 ⁺⁰ _{+0.2}	5.0 ⁺⁰ _{+0.2}	5.0 ⁺⁰ _{+0.2}
φ 55.0	16x10xC	15x10xC	6.0 ⁺⁰ _{+0.2}	4.3 ⁺⁰ _{+0.2}	5.0 ⁺⁰ _{+0.2}	5.5 ⁺⁰ _{+0.2}
φ 65.0	18x11xC	18x12xC	7.0 ⁺⁰ _{+0.2}	4.4 ⁺⁰ _{+0.2}	6.0 ⁺⁰ _{+0.2}	6.5 ⁺⁰ _{+0.2}
φ 75.0	20x12xC	20x13xC	7.5 ⁺⁰ _{+0.2}	4.9 ⁺⁰ _{+0.2}	7.0 ⁺⁰ _{+0.2}	6.5 ⁺⁰ _{+0.2}
φ 90.0	25x14xC	24x16xC	9.0 ⁺⁰ _{+0.2}	5.4 ⁺⁰ _{+0.2}	8.0 ⁺⁰ _{+0.2}	8.5 ⁺⁰ _{+0.2}
φ 100.0	28x16xC	28x18xC	10.0 ⁺⁰ _{+0.2}	6.4 ⁺⁰ _{+0.2}	9.0 ⁺⁰ _{+0.2}	10.0 ⁺⁰ _{+0.2}
φ 115.0	28x16xC	28x18xC	10.0 ⁺⁰ _{+0.2}	6.4 ⁺⁰ _{+0.2}	9.0 ⁺⁰ _{+0.2}	10.0 ⁺⁰ _{+0.2}

相關計算 CALCULATE DATA

(A) 連結系數表 (CONNECTION FACTOR)

鏈輪 SPROCKET	1.00
齒輪 GEAR	1.25
三角皮帶 BELT	1.50
平皮帶 FLAT BELT	2.50

(B) 荷重系數表 (SERVICE FACTOR)

減速機負載等級 LOAD GRADE	每日運轉時間 (HRS) DAILY OPERATING HOURS			
	1-2	3-8	9-15	16-24
均一負載 UNIFORM LOAD	0.80	0.90	1.20	1.30
中級重擊負載 MEDIUM IMPACT LOAD	1.00	1.20	1.30	1.50
重級重擊負載 HEAVY IMPACT LOAD	1.20	1.50	1.75	2.00

(C) 符號說明 (CODE DETAILS)

V=速度 SPEED (M/MIN)	E=效率 EFFICIENCY (%)	1 INCH=2.54cm
I=減速比 RATIO	N2=出力軸轉速 (RPM) OUTPUT SHAFT SPEED	1 FOOT=12 INCH
T=輸出扭力 (KG-M) OUTPUT TORQUE	D=滾輪直徑 (mm) ROLLER DIAMETER	1KW=1000W 1KW=1.34HP
K=連結系數 CONNECTING FACTOR	R=滾輪半徑 (mm) ROLLER RADIUS	1KG-M=7.233 FT-LB 1KG-M=86.8 IN-LB
F=荷重系數 SERVICE FACTOR	KW1 (HP1)=入力馬力 INPUT CAPACITY	1KG=2.2 LB 1 LB=0.4536KG
W=荷重 (KG) LOAD	KW2 (HP2)=輸出馬力 OUTPUT CAPACITY	N1=入力回轉速 (r/min) INPUT SHAFT ROTATION SPEED

(D) 基本傳動公式 (BASIC FORMULAR)

減速比 RATIO	I=N2/N1
回轉速度 ROTATION SPEED (r/min)	N2=V/πD
輸出扭矩 OUTPUT TORQUE (KG-M)	T=WxRxK
輸入馬力 INPUT HORSEPOWER (公制 METRIC)	KW1=NxTx974
輸入馬力 INPUT HORSEPOWER (英制 INCH)	HP1=NxT/716
輸出馬力 OUTPUT HORSEPOWER (公制 METRIC)	KW2=KW1x F/E
輸出馬力 OUTPUT HORSEPOWER (英制 INCH)	HP2=HP1x F/E

(E) 減速機水平輸送場合符號說明及傳動公式 (DESCRIPTION AND TRANSMISSION)

輸送速度 (r/min) TRANSMISSION SPEED	V	輸送帶摩擦係數 BELT FRICTION COEFFICIENT	μ
滾輪直徑 (mm) ROLLER DIAMETER	D	鏈輪傳動效率 (%) CHAIN DRIVE EFFICIENCY	η1
載重量 (KG) LOAD	W	減速機傳動效率 (%) REDUCER TRANSMISSION	η2=0.9
出力軸主動鏈輪齒數 OUTPUT SHAFT TEETH	T1	輸送機被動鏈輪齒數 CONVEYOR PASSIVE SPROCKET TEETH	T2
輸送帶所需扭力 (KG-M) BELT TORQUE	T1	減速機減速比 REDUCER RATIO	I
減速機扭力 (KG-M) REDUCER TORQUE	T2	減速機出力軸回轉速 (r/min) REDUCER OUTPUT SHAFT ROTATION SPEED	N2
荷重系數 SERVICE FACTOR	F (查4-13表 (B)) F (FIND 4-13 TABLE(B))		

輸送機回轉速 (r/min) TRANSMISSION SPEED	N1=V/πD
減速機出力軸回轉速 (r/min) REDUCER OUTPUT SHAFT ROTATION SPEED	N2=N2X(T2/T1)
減速機減速比 (1) REDUCER RATIO	50HZ I=1500/N2 60HZ I=1800/N2
輸送帶所需扭力 (KG-M) BELT TORQUE	T1=WxD/2Xμ/η1
減速機所需扭力 (KG-M) REDUCER TORQUE	T2=t1X(t1/t2)/η2
考慮荷重系數減速馬達扭力 GEAR MOTOR TORQUE (SERVICE FACTOR BE CONSIDER)	T3=t3x F
馬力 (HP) CAPACITY	HP=t3xN2/716.2

4-2 輸出扭矩表 OUTPUT TORQUE

標準型 (NORMAL DUTY TYPE)

KG-M

減速比 RATIO	輸出轉速 OUTPUT R.P.M		輸出扭矩 OUTPUT TORQUE													
			0.1KW		0.2KW		0.4KW		0.75KW		1.5KW		2.2KW		3.7KW	
	HZ															
	50	60	50	60	50	60	50	60	50	60	50	60	50	60	50	60
3	500	600	0.19	0.16	0.37	0.31	0.70	0.60	1.30	1.10	2.60	2.20	3.80	3.20	6.00	5.50
5	300	360	0.31	0.26	0.62	0.52	1.20	1.00	2.20	1.90	4.50	3.80	6.72	5.60	11.0	10.0
10	150	180	0.62	0.52	1.24	1.04	2.40	2.00	4.50	3.80	9.10	7.60	13.7	11.2	22.0	20.0
15	100	120	0.91	0.76	1.80	1.50	3.60	3.00	6.80	5.70	13.5	11.3	20.1	16.8	32.6	29.8
20	75	90	1.20	1.00	2.40	2.00	4.80	4.00	9.00	7.50	18.1	15.1	26.8	22.4	43.6	36.0
25	60	72	1.40	1.20	3.00	2.50	6.00	5.00	11.2	9.40	22.6	18.9	33.6	28.0	53.9	49.53
30	50	60	1.80	1.50	3.60	3.00	7.20	6.00	13.5	11.3	27.1	22.6	40.3	33.6	64.7	58.8
40	37	45	2.20	1.90	4.60	3.90	9.30	7.80	17.5	14.6	34.9	29.1	52.0	43.4	86.3	78.4
45	33	40	2.70	2.20	5.40	4.40	10.9	9.10	20.6	17.0	41.1	34.0	59.8	49.6	98.5	81.7
50	30	36	2.80	2.40	5.70	4.80	11.6	9.70	21.9	18.3	43.6	36.4	65.1	54.3	107	97.0
60	25	30	3.40	2.90	6.90	5.80	13.9	11.6	26.2	21.9	52.4	43.7	78.1	65.1	127	115
70	21	25	4.30	3.60	8.00	6.80	16.2	13.5	31.5	26.3	62.4	52.0	92.5	77.1		
80	19	23	4.80	4.00	9.20	7.70	18.4	15.4	35.5	29.6	70.8	59.0	105	87.5		
90	17	20	5.20	4.40	10.3	8.60	20.7	17.3	39.3	32.8	77.1	64.3	113	94.3		
100	15	18	5.80	4.90	11.5	9.60	23.0	19.2	43.2	36.0	83.7	69.8	126	105		
120	12	15	6.90	5.80	13.8	11.5	27.7	23.1	51.8	43.2	101	83.7				
140	11	13	8.00	6.70	16.0	13.4	32.0	26.7	59.7	49.8	116	96.8				
160	9	11	9.10	7.60	18.3	15.3	36.3	30.3	68.0	56.7	132	110				
180	8	10	10.3	8.60	20.7	17.3	40.8	34.0	76.8	64.0	148	123				
200	7	9	11.6	9.70	22.9	19.1	43.2	36.0	82.8	69.0						

4-3 出力轉懸垂荷重 OVERHUNG LOAD

KG

減速比 RATIO	輸出轉速 OUTPUT R.P.M		出力轉懸垂荷重													
			0.1KW		0.2KW		0.4KW		0.75KW		1.75KW		2.2KW		3.7KW	
	HZ															
	50	60	50	60	50	60	50	60	50	60	50	60	50	60	50	60
3	500	600	30	25	30	25	54	45	60	50	145	130	165	150	200	180
5	300	360	36	30	36	30	78	70	85	75	165	150	210	180	270	225
10	150	180	70	60	70	60	150	130	180	150	280	250	430	360	570	550
15	100	120	110	90	110	100	175	160	165	160	355	348	490	450	780	750
20	75	90	150	125	135	125	190	170	175	170	369	365	540	500	850	830
25	60	72	155	140	150	140	210	180	185	180	450	430	650	630	1100	1050
30	50	60	160	150	170	165	235	220	415	400	480	450	690	650	1200	1100
40	38	45	160	160	180	180	270	260	430	420	580	550	710	670	1280	1200
45	33	40	170	170	180	180	335	328	440	430	590	570	820	780	1300	1250
50	30	36	170	170	180	180	350	335	450	440	600	580	850	820	1400	1350
60	25	30	180	180	180	180	350	350	450	450	630	610	900	900	1400	1400
70	21	25	180	180	180	180	350	350	460	460	670	650	1100	1100		
80	18	22	180	180	180	180	350	350	460	460	680	680	1100	1100		
90	16	20	180	180	180	180	350	350	500	500	850	850	1200	1200		
100	15	18	200	200	250	250	380	380	590	590	900	900	1200	1200		
120	12	15	200	200	320	320	390	390	640	640	920	920				
140	11	13	200	200	320	320	400	400	679	679	920	920				
150	10	12	220	220	330	330	420	420	679	679	950	950				
160	9	11	220	220	330	330	420	420	700	700	950	950				
180	8	10	240	240	350	350	430	430	720	720	980	980				
200	7	9	240	240	350	350	430	430	720	720						
1/250~1/1800			300	300	480	480	720	720	1400	1400						

4-4 出力軸允許最大軸徑 AVAILABLE MAX OUTPUT SHAFT DIAMETER

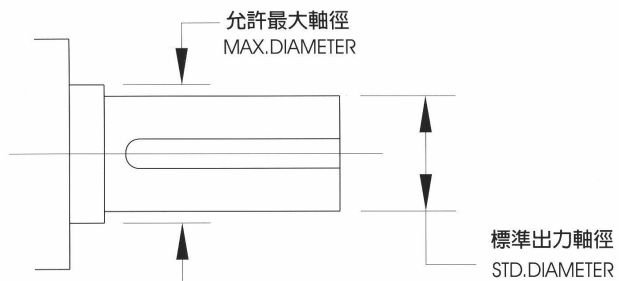

本體框號 HOUSING CODE	標準出力軸徑 STD OUTPUT SHAFT	出力軸培林 OUTPUT SHAFT BEARING	允許最大軸徑 MAX AVAILABLE SHAFT DIAMETER
1#	φ 18.0	6004	φ 20.0
2#	φ 22.0	6205	φ 25.0
3#	φ 28.0	6206	φ 30.0
4#	φ 32.0	6207	φ 35.0
5#	φ 40.0	6209	φ 45.0
5#	φ 45.0	6209	φ 45.0
6#	φ 50.0	6211	φ 55.0

4-5 出力軸軸徑對照表 OUTPUT SHAFT DIAMETER TABLE

標準型 (NORMAL DUTY TYPE)

馬力 CAPACITY	1/8HP (100W)	1/4HP (200W)	1/2HP (400W)	1HP (750W)	2HP (1500W)	3HP (2200W)	5HP (3700W)
速比 RATIO							
3	18	18	22	28	32	40	40
5	18	18	22	28	32	40	40
10	18	18	22	28	32	40	40
15	18	22	28	28	32	40	40
20	18	22	28	28	32	40	50
25	18	22	28	28	32	40	50
30	18	22	28	32	32	40	50
40	18	22	28	32	40	40	50
45	18	22	28	32	40	50	50
50	18	22	28	32	40	50	50
60	22	22	28	32	40	50	50
70	22	22	28	32	40	50	
80	22	22	28	32	40	50	
90	22	22	28	32	40	50	
100	22	28	32	32	40	50	
120	22	28	32	32	50		
140	22	28	32	40	50		
150	22	28	32	40	*50		
160	22	28	32	40	*50		
180	22	28	32	40	*50		
200	22	28	32	40			
250-1800	28	32	40	50			

輕負載縮框型 LIGHT DUTY TYPE

馬力 CAPACITY	1/8HP (100W)	1/4HP (200W)	1/2HP (400W)	1HP (750W)	2HP (1500W)	3HP (2200W)	5HP (3700W)
速比 RATIO							
3				22	28		
5				22	28		
10				22	28		
15		18	22	22	28		40
20			22	22	28		40
25			22	22	28		40
30		18	22	28	28		40
40		18	22	28	32		40
45		18	22	28	32		40
50		18	22	28	32	40	40
60	18	18	22	28	32	40	40
70	18	18	22	28	32	40	
80	18	18	22	28	32	40	
90	18	18	22	28	32		
100	18	22	28	28	32		
120	18	22	28	28	40		
140	18	22	28	32	40		
150	18	22	28	32	40		
160	18	22	28	32	40		
180	*18	22	28	32	*40		
200	*18	22	*28	*32			
250-1800	22	28	32	40			

備注
REMARK

- 縮框機型為不正當設計使用，如非必要請勿選用
LIGHT DUTY TYPE ARE NOT AVAILABLE FOR STANDARD APPLICATION DESIGN, IT ONLY SUITABLE FOR SPECIAL PROJECT DESIGN
- 僅就馬達部份提供一年保固，PROVIDE ONE YEAR GUARANTEE FOR MOTOR ONLY
- *為達到此速比時必須搭配6P馬達使用。*IT NEED TO USE 6 POLE MOTOR TO REACH CEFTAIN RATIO.

4-6公稱及實際速比 (NORMAL RATIO&ACTUAL RATIO)

標準型 (NORMAL DUTY TYPE)

公稱速比 NORMAL RATIO	低段實際減速比 ACTUAL RATIO						
	0.1KW	0.2KW	0.4KW	0.75KW	1.5KW	2.2KW	3.7KW
3	3.04	3.04	2.99	2.92	3.05	3.25	3.25
5	5.07	5.07	5.14	5.03	5.01	5.19	5.19
10	10.03	10.03	10.01	9.96	10.41	9.48	9.48
15	15.09	15.60	15.61	15.31	14.33	15.71	14.62
20	19.90	19.90	20.69	19.49	19.35	19.38	19.58
25	26.81	25.65	26.35	25.27	25.08	23.71	24.54
30	30.06	32.77	29.81	30.00	29.38	29.25	30.87
40	40.33	40.46	39.11	40.99	43.72	41.83	41.77
50	50.59	49.42	50.21	51.24	50.96	50.51	50.51
60	58.64	63.02	61.36	58.10	61.83	58.48	58.48
70	71.62	71.31	71.15	72.00	72.87	67.65	
80	80.19	81.23	77.13	79.99	80.30	81.18	
90	91.34	92.69	94.27	90.00	90.54	93.99	
100	102.27	104.62	103.70	99.99	103.05	98.17	
110		109.02		108.00	***109.20		
115	115.71				117.00		
120	117.73	123.33	116.66	120.00	122.20		
130	131.81	133.25	129.62	133.79	***126.30		
140	134.81	141.32	140.00				
150	150.41	150.74		150.41	***151.56		
160	162.73	162.86	155.55	160.70	***158.30		
170	168.40	172.73			***175.50		
180	182.19	182.32	175.00	180.01	***183.30		
200	192.83	193.37	194.44	216.22			
備注 REMARK	***為達到此速比時，必需搭配6P馬達使用 ***IT NEED USE 6 POLE MOTOR TO REACH CERTAIN RATIO						

公稱速比 NORMAL RATIO	低段實際減速比 ACTUAL RATIO						
	0.1KW	0.2KW	0.4KW	0.75KW	1.5KW	2.2KW	3.7KW
250	258.02	267.07	250.05	244.62			
	306.03	304.74	282.89	299.84			
350	354.98	367.70	357.57	359.81			
400	389.75	377.61	401.21	381.87			
450	468.00	435.77	468.71	458.24			
500	528.35	496.40	510.97	518.42			
600	600.78	566.42	605.37	602.14			
700	700.07	704.66	701.91	703.57			
800	825.28	805.32	810.36	814.66			
900	922.95	894.80	893.94	921.64			
1000	1008.09	1036.04	1014.40	985.00			
1100	1097.35	1118.51	1102.53	1114.35			
1200	1224.82	1172.26	1214.91	1199.37			
1300	1329.80	1291.19	1298.22				
1400	1374.44	1393.98					
1500	1517.32	1540.55	1484.89	1492.43			
1600	1582.76	1613.99	1574.88	1612.36			
1650							
1700	1711.73	1685.55	1728.08				
1800	1775.20	1838.52	1821.00	1832.99			

輕負載縮框型 LIGHT DUTY

公稱速比 NORMAL RATIO	低段實際減速比 ACTUAL RATIO						
	0.1kW	0.2kw	0.4KW	0.75KW	1.5KW	2.2KW	3.7KW
3				2.99	2.93		
5				5.14	5.03		
10				10.01	9.96		
15		15.09	15.06	15.06	15.03		15.71
20		19.90	20.14	20.14	19.49		19.37
25		26.81	26.18	26.18	25.27		23.72
30		30.06	29.31	28.93	28.93		29.25
40		40.33	44.20	43.07	41.64		41.82
50		50.59	56.38	52.64	52.05	51.97	51.96
60	60.49	60.49	56.37	57.06	57.33	59.15	59.13
70			72.67	69.75	71.66	70.23	
80			82.92	82.22	77.40	79.93	
90	89.62	89.62	92.81	88.83	86.00		
100		103.78	98.24	100.49	107.50		
120	122.49	116.20	120.07	115.15	121.67		
140	140.41	133.05	135.83	135.00	136.26		
160	161.33	162.73	155.64	150.00	163.70		
180	***183.74	183.17	174.24	***180.00	***182.50		
200	***210.62	215.87		***202.50	***204.39		
備注 REMARK	***為達到此速比時，必需搭配6P馬達使用 ***IT NEED USE 6 POLE MOTOR TO REACH CERTAIN RATIO						

公稱速比 NORMAL RATIO	低段實際減速比 ACTUAL RATIO						
	0.1kW	0.2kw	0.4KW	0.75KW	1.5KW	2.2KW	3.7KW
250	255.98	258.02	255.16	264.54			
300	300.50	291.90	300.12	299.28			
350	340.03	354.98	344.47	356.29			
400	396.18	389.75	389.76	401.72			
450		467.84	443.98	457.24			
500	510.63	528.35	493.38	519.30			
600	610.64	600.78	594.88	599.53			
700	687.84		717.74	705.75			
800	802.78	825.28	800.32	815.69			
900	908.34		884.57	922.80			
1000	1007.13	1052.10	1000.40	1016.86			
1200	1321.92	1224.82	1200.48	1210.37			
1500	1485.90	1523.73	1500.61	1484.37			
1800	1810.42	1771.61	1775.94	1775.2			

4-7 潤滑油 LUBRICANT

本公司于出廠前已添加潤滑油脂 (BT-860-0),在正常條件下運轉20,000小時可不比更換潤滑油脂,但在特殊環境下運轉時,如:高溫,長時間運轉,動擊負荷等,則換油頻率為10,000-15,000小時。

ALL REDUCERS FILLED WITH LUBRICANT(BT-860-0)BEFORE DELIVERY,NORMALLY,IT NO NEED TO REPLACE LUBRICANT FOR FIRST 20,000 HRS RUNNING,BUT IF WORKING IN SPECIAL APPLICATION,SUCH AS:HIGH TEMPERATURE, 24 HRS RUNNING,HEAVY DUTY IMPAT....etc,THEN LUBRICANT NEED TO BE CHANGED IN EVERY 10,000-15,000 WORKING HOURS.

油量表/重量表 (LUBRICANT/WEIGHT TABLE)

馬力 CAPACITY	出力軸 OUTPUT SHAFT	本體框號 HOUSING CODE	機型TYPE								
			油量表 (公升) LUBRICANT(L)		重量表 (公斤) WEIGHT(KG)						
			CH CHM CHD	CV CVM CVD	CH	CHM	CHD	CV	CVM	CVD	
100W 1/8HP	Φ18	1#	0.19	0.18	5.60	5.22	2.90	5.80	5.12	2.80	
	Φ22	2#	0.38	0.39	7.30	6.40	4.00	7.30	6.52	4.10	
	Φ28	1#+3#	0.8	0.85	14.6	12.4	11.3	14.6	12.52	11.4	
200W 1/4HP	Φ18	1#	0.18	0.18	7.00	5.22	2.90	7.00	5.12	2.80	
	Φ22	2#	0.38	0.39	8.60	6.42	4.00	8.80	6.52	4.10	
	Φ28	3#	0.63	0.68	11.0	9.12	8.30	10.8	8.92	8.10	
400W 1/2HP	Φ32	2#+4#	1.30	1.40	27.6	24.0	23.0	28.0	24.4	22.8	
	Φ22	2#	0.38	0.39	11.1	6.42	4.80	11.2	6.52	4.90	
	Φ28	3#	0.63	0.68	14.2	9.12	8.30	14.0	8.92	8.10	
750W 1HP	Φ32	4#	0.95	1.05	27.0	22.2	21.5	26.9	23.2	22.5	
	Φ40	3#+5#	1.80	1.90	46.0	39.8	39.1	47.0	40.8	40.1	
	Φ28	3#	0.63	0.68	15.5	12.1	8.30	15.0	11.9	8.10	
1500W 2HP	Φ32	4#	0.95	1.05	33.6	25.0	22.0	34.6	26.0	23.0	
	Φ40	5#	T	1.470	1.590	49.6	37.3	33.0	49.0	36.3	32.0
			TT	1.260	1.470						
	Φ50	6#	2.520	2.600	94.0	74.3	70.0	94.0	71.3	67.0	
Φ50	4#+6#	3.470	3.650	105.0	--	--	106.0	--	--		
2200W 3HP	Φ40	5#	D	1.680	1.800	49.0	40.8	36.5	51.0	39.8	35.5
			T	1.490	1.590						
	Φ50	6#	2.520	2.600	92.5	77.8	73.5	88.5	74.8	70.5	
3700W 5HP	Φ40	5#	1.680	1.800	54.8	43.8	39.5	55.3	42.8	38.5	
	Φ50	6#	2.520	2.600	98.5	78.8	74.5	94.5	75.8	71.5	

備註: 1、此表僅供參考,具體以實物為準
1、THIS TABLE IS FOR REFERENCE ONLY SUBJECT TO THE SPECIFIC KIND

4-8 速比/段數使用表 RATIO/GEAR STAGE TABLE

馬力 CAPACITY	速比 RATIO	雙段 (D) 2 ND STAGE	三段 (T) 3 ND STAGE	雙本體 1#+3# TWIN HOUSING	雙本體 2#+4# TWIN HOUSING	雙本體 3#+5# TWIN HOUSING	雙本體 3#+6# TWIN HOUSING
1/8HP (100W)	1/3-1/50	D					
	1/60-1/200		T				
	1/150、 180、200		T				
	1/250-1/1800			DD			
1/4HP (200W)	1/3-1/35	D					
	1/40-1/200		T				
	1/60、180、200		T				
	1/250-1/1800				DD		
1/2HP (400W)	1/3-1/35	D					
	1/40-1/200						
	1/250-1/1800				DD		
1HP (750W)	1/3-1/30	D					
	1/40-1/120		T				
	1/125-1/200		(TT)				
	1/250-1/1800						DD
2HP (1500W)	1/3-1/22	D					
	1/25-1/50		T				
	1/55-1/100						
	1/105、 115、120		T				
	1/100-1/180		T				
3HP (2200W)	1/3-1/15	D					
	1/20-1/100		T				
5HP (3700W)	1/3-1/25	D					
	1/30-1/60		T				

**馬達到以下速比時,必需搭配6P馬達使用TO REACH CERTAIN RATIO THAT NEED TO USE 6 POLE MOTOR

2HP	1/130、1/150、1/160、1/170、1/180
-----	-------------------------------

4-9 接線方式 WIRING DIAGRAM

(1) 三相馬達/剎車器接線方式 (THREE PHASE MOTOR W/BRAKE UNIT DIAGRAM)

(a) 三相六條馬達電源線 (FOR SIX WIRES)

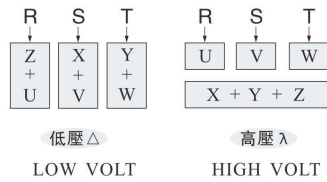

(b) 三相九條馬達電源線 (FOR SIX WIRES)

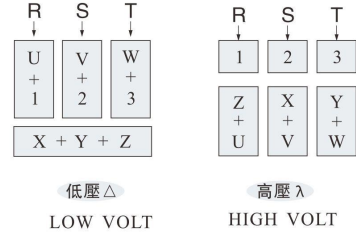

(c) 三相六條馬達電源線交流剎車器 (SIX WIRES W/ AC BRAKE UNIT)

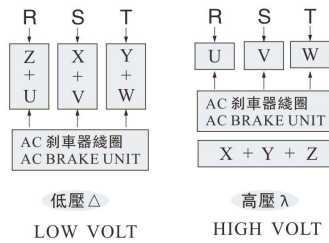

(d) 三相九條馬達電源線交流剎車器 (NINE WIRES W/ AC BRAKE UNIT)

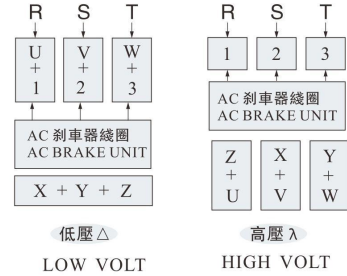

(e) 六條馬達電源線直流剎車器 (SIX WIRES W/ DC BRAKE UNIT)

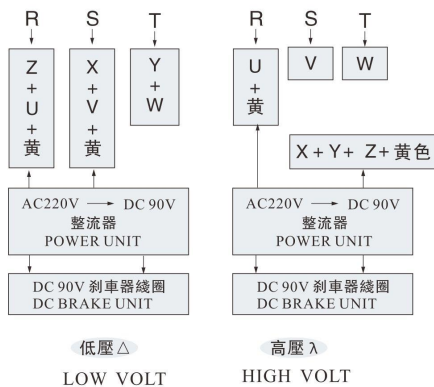

(f) 九條馬達電源線直流剎車器 (NINE WIRES W/ DC BRAKE UNIT)

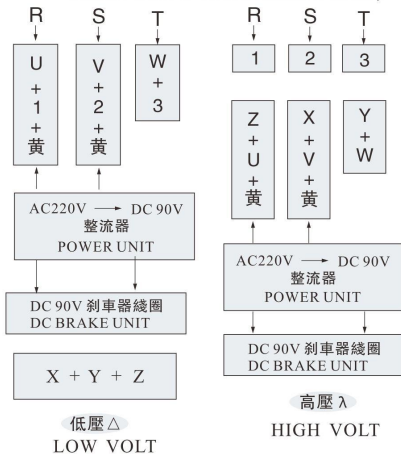

(2) 單相馬達/剎車器接線方式 (SINGLE PHASE MOTOR W/BRAKE UNIT DIAGRAM)

(a) 單相低壓 LOW VOLTAGE-110V

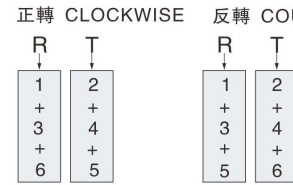

(b) 單相高壓 HIGH VOLTAGE-220V

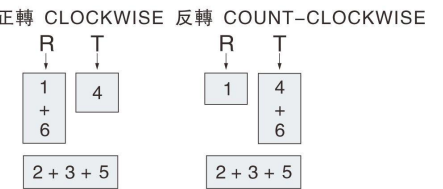

(c) 單相低壓 110V 直流剎車器 LOW VOLTAGE 110V WITH DC BRAKE UNIT

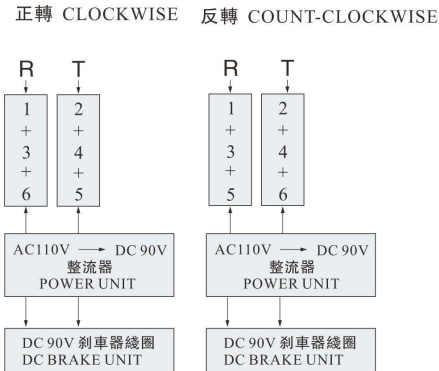

(d) 單相高壓 220V 直流剎車器 HIGH VOLTAGE 220V WITH DC BRAKE UNIT

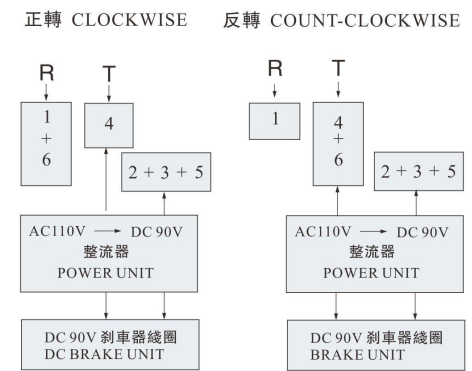

(3) 加溫控接線方式 (TEMPERATURE CONTROL WIRING)

(a) 三相馬達加溫控接線圖 3-PHASE THERMOSTAT WIRING DIAGRAM

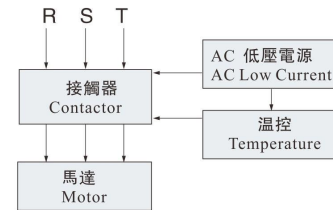

(b) 單相馬達加溫控接線圖 1-PHASE THERMOSTAT WIRING DIAGRAM

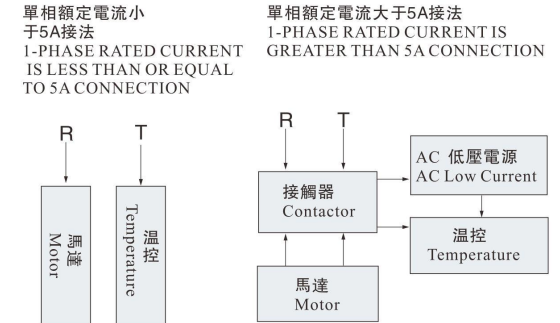

剎車裝配圖

Braking assembly drawing

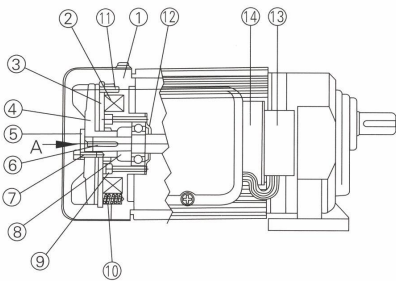

- 1、剎車主體 Braking main body
- 2、剎車激勵繞圈 Braking excitation coil
- 3、來令片 Lining
- 4、散熱風葉 Radiator
- 5、調整螺栓 Calibrating bolt
- 6、單圓鍵 Single round parallel key
- 7、固定螺絲 Set screws
- 8、墊圈 Washer
- 9、套筒螺絲 Telescopic screw
- 10、壓縮彈簧 compression spring
- 11、彈簧梢 Spring pin
- 12、軸承蓋 Bearing cap
- 13、整流器 Rectifier
- 14、整流器鐵板 The iron plate rectifier

剎車零件分解圖 (BRAKE UNIT SECTION DIAGRAM)

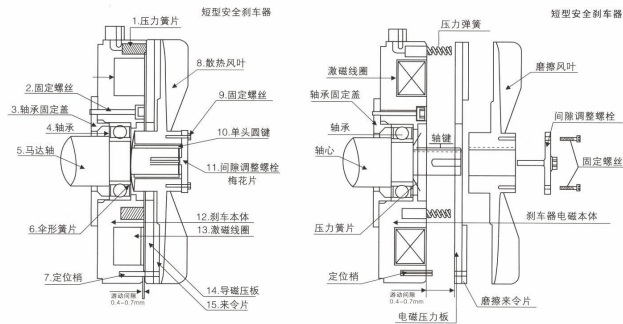

- 1、壓力彈簧 PRESSURE SPRING
- 2、固定螺絲 FIXED SCREW
- 3、軸承固定蓋 FIXED BEARING PLATE
- 4、軸承 BEARING
- 5、馬達軸 MOTOR SHAFT
- 6、傘形簧簧片 DISC SPRING
- 7、定位銷 FIXED PIN
- 8、散熱風葉 FAN
- 9、固定螺絲 FIXED SCREW
- 10、固定鍵 KEY
- 11、調整螺栓 GAP ADJUSTMENT BOLT
- 12、煞車本體 BRAKE HOUSING
- 13、激勵繞圈 BRAKE COIL
- 14、導磁壓板 FRICTION PLATE
- 15、來令片 FRICTION BRAKE DISC

剎車間隙調整 (ADJUST BRAKE CLEARANCE)

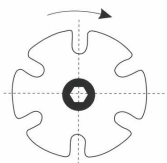

- 1、請先移除固定螺絲
PLEASE REMOVE TWO PIECES FIXED SCREWS IN ADVANCE.
- 2、順時針調整一格，其間距縮小0.07-0.10mm。
EVERY SINGLE POSITION ADJUSTMENT, BRAKE CLEARANCE WILL REDUCE 0.07-0.10mm

剎車間隙調整原因：

The reason of calibrating braking gap:

- 1、每當使用一段時間剎車動作不正確時。
- 2、至少每年需要調整剎車間隙一次。
- 3、依使用的頻率多寡，可自行決定調整間隙的次數。
- 4、請使用厚薄規調整剎車間隙在0.3-0.5mm之間。

間隙調整方法：

The way of gap calibration:

- 1、打開馬達風蓋，拆掉調整螺栓上兩個固定螺絲。
- 2、旋轉調整螺栓可調整剎車間隙。順時針---縮小間隙，逆時針---放大間隙，每等距調整約0.2mm。
- 3、以厚薄規調整好間隙後，將調整螺栓上四個或六個孔之其中對角兩孔固定將固定螺絲鎖緊即完成調整間隙動作，其所調整方法及所需間隙厚薄規為準。

- 1、When braking action is not right after using for some time.
 - 2、Braking gap needs to be adjusted once a year at least.
 - 3、The frequency of calibration gap can be determined automatically according to use frequency.
 - 4、Please use thickness gauge to calibrate braking gap between 0.3-0.5mm.
- 1、Open wind cover of the motor and dismantle two fixed screws on calibration bolt.
 - 2、Rotate and calibrate bolt to calibrate braking gap. Clockwise shorten the gap, counterclockwise-enlarge the gap, with every isometry calibration of 0.2mm.
 - 3、After the gap is calibrated with thickness gauge, the diagonal holes among four or six holes in calibration bolt are fixed, and fixed screws are fixed to complete gap calibration, and it refers to calibration method and gap determined by thickness gauge.

特長 Strong suits

- 斷電時動作.....無激磁作動剎車，斷電時自動剎車動作。
Action after power off.....without excitation action braking, with automatic braking action when power off
- 接線容易.....整流器裝于馬達外殼上，接交流電源。
Easy connection.....rectifier installed on the shell of motor, connecting AC power.
- 小型重量輕.....加裝剎車所增加馬達長度極少，體積小，重量輕。
Small-size and lighter.....the length of motor increased from adding brake is very little, small volume, light weight.
- 壽命長.....剎車來令片材質耐磨耗性佳，剎車動作正確，調整方便。
Long service life.....the material of the lining has good endurance, with correct braking action, easy calibration.

剎車規格標準 Braking specification standard

輸出電壓 Output voltage	三相剎車齒輪減速馬達 Three-phase braking gear reduction motor	單相剎車齒輪減速馬達 Single-phase braking gear reduction motor
輸出電壓 Discharge voltage	AC200/208/220V-50/60HZ	AC100/100/-50/60HZ
輸出電壓 Output voltage	DC90/108V	DC90/180V
周圍環境溫度 Ambient temperature	-10°C~+40°C	
絕緣耐壓 Insulated and pressure resistance	AC1500V	

接線圖

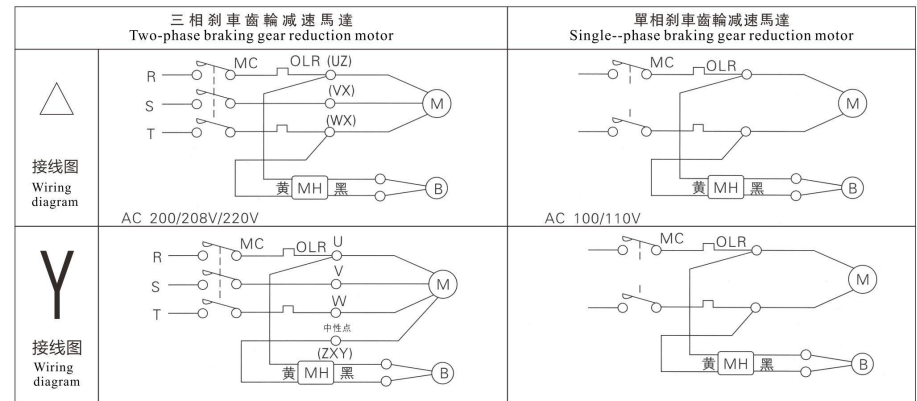

- M----馬達 Motor
- B----剎車 Brake
- MH---整流器 Rectifier
- MC----電磁接觸器 Electromagnetic connector
- OLR-----過負荷繼電器 Overload relay

注：剎車馬達接變頻器使用，剎車繞圈可能產生吸合不良，剎車繞圈可直接銘牌標注的市電。

Note: braking motor is connected to transducer, and braking coil may generate bad actuation, and braking coil can be marked directly.

三相齒輪減速馬達接線圖 Three-phase gear reduction motor wiring diagram

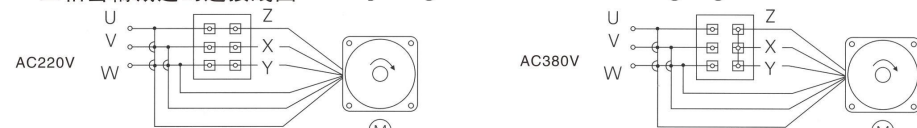

單相齒輪減速馬達接線圖 Single-phase gear reduction motor wiring diagram

